

Heater chains for the ITER Current Lead Terminals

Call for Nomination

Purpose

This contract concerns the supply of several types of Electrical Heaters to heat the Current Leads (CL) terminal used for powering the superconducting magnets of the ITER machine in order to avoid heavy condensation or ice formation.

Background

The current leads for the ITER machine are optimized for operation at the nominal current. The optimal cross-section/length of the current leads and the enhanced heat transfer to the cooling helium gas (GHe) by the integrated heat exchanger (HEX) ensure that the GHe at the exit in warm terminals (Figure 1) of the current leads is naturally maintained at ambient temperature conditions.

Because they are designed for the nominal electric current level, the CLs will be overcooled during stand-by conditions. Although the cold end temperature can be increased to compensate the excessive cooling during stand-by mode, it is desirable to keep the stand-by condition close to nominal so that the CLs does not lose its insulation strength. Therefore electrical heating at the warm terminals are provisioned to compensate the overcooling at standby condition. For the TF coil CL at 68kA, a heating power of 2~3 kW is estimated for each warm terminal and 300 W in case of the CL in CC coil. The warm terminals are designed to allow insertion of rod type insulated cartridge heaters into the terminal body. In such conditions the heaters will stay at the room temperature.

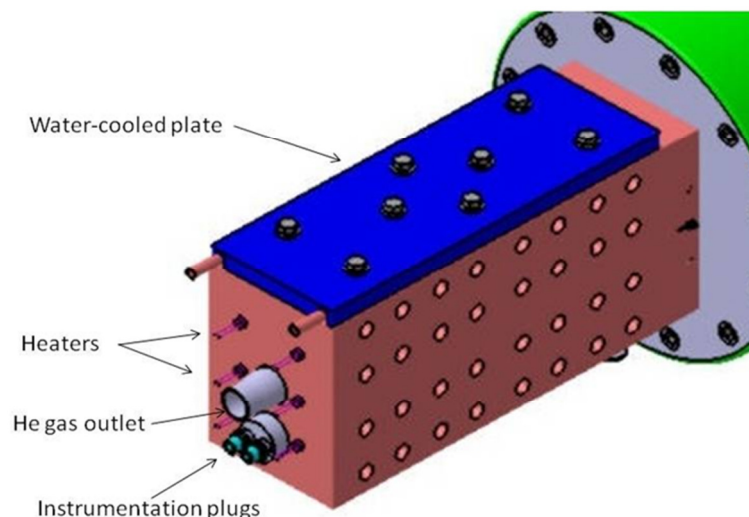

Figure 1: View of the warm CL terminal on the 68 kA lead

Scope of work

The Figure 2 gives a functional picture of the heater chain. This chain is made of following components:

- The heating function is implemented by heating cartridges (1). Insulated heating cartridges are installed or inserted into the CL terminal (9) and locked mechanically in that position. The surface of the heating cartridges is electrically insulated from the CL terminal. There may be several heating cartridges in one CL terminal. The heating cartridge is designed to provide thermal power by conduction to the CL terminal.
- The insulated heating cartridge (1) is electrically connected by a cable (2) to an interface block (4). The heating cartridge is delivered with its cable already connected to and equipped with a connector/plug (3) for being easily replaced for maintenance. All the components referenced 1, 2, 3 and 4 are installed into a Dry-box (10). The main purpose of the Dry-box is to protect the CL terminals against moisture and electrical breakdown to the earth ground. The Dry-box metal enclosure is connected to the earth ground in order to maintain ground potential.
- The function of the interface block is to connect all the cartridge cables of a same CL terminal to a power supply cable (11) The interface block (4) shall be delivered with a power cable plug (5) . There will be one interface block (4) on one CL terminal (9).
- The power cable (11) is connected to a power supply (6) installed into a cubicle (12). There will be one power supply (6) connected to one and only one CL terminal (9). There may be several power supplies (6) within a cubicle (12). The power supplies (6) are supplied by a main supply power line (8) and are interfaced to the magnet control system (7).
- In addition to the heating cartridge power supplying function, the power supply devices shall be designed to have following control and monitoring functions:
- Over-current protection for being protected against heating cartridge internal short.
- Heating control and heating cartridge health monitoring. These control and monitoring functions are interfaced to the magnet control system for states and controls. The control/monitoring interface is part of the power supply delivery.

The contract scope of supply for hardware components is made of items 1, 2, 3, 4, 5(optional) and 6. The items 7, 8, 9, 10, 11 and 12 are NOT in the scope of this contract.

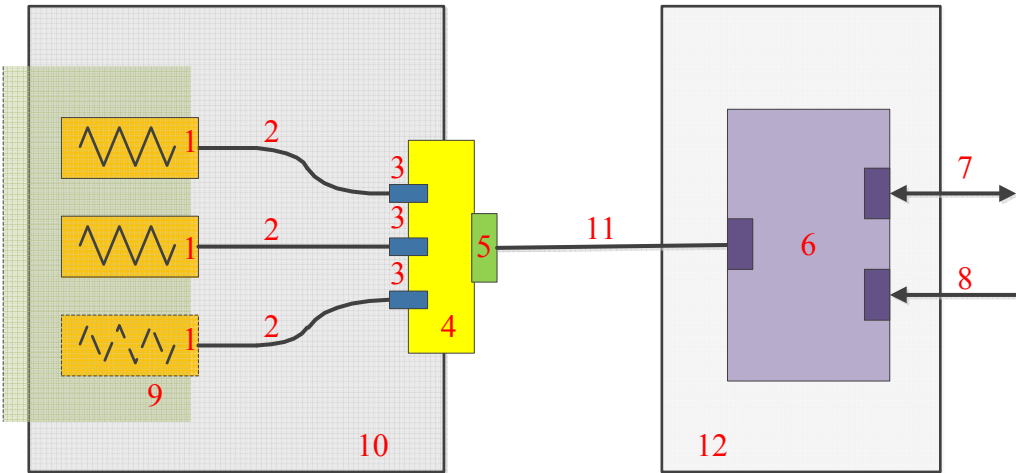

Figure 2 Whole heater loops from Heater to Power Supply

Supplying Products

(1) Insulated Heating Cartridge

IO has developed a prototype version and qualified it. The related document “Test report of HV insulated heating cartridge for IO Current lead terminal block” will be provided after the contract signed.

- *Heating power & Operation voltage:*
 - Input voltage : 230V (DC)
 - Heating Power of type 1& 2 : 500W
 - Heating Power of type 3 : 200W
- *Heating cartridge Material:*
The heating cartridges will be installed in an environment subject to gamma radiation, at the level of 100 kGy. No specific radiation tolerance beyond that of standard G10 material or stainless steel is specified
- *Heating cartridge cable:*
It should be compatible with the connection interface block connector. The length of the power cable shall be 2m. This cable doesn't need to have any high voltage strength.
- *Size, Shape and tolerance:* Circular cross section
 - Diameter of type 1&2 : 17.8 mm ± 0.05mm
 - Diameter of type 3 : 14.8 mm ± 0.05mm
 - Length of type 1 & 2 : 500 mm ± 1mm except plug
 - Length of type 3 : 250 mm ± 1mm except plug
 - Straightness of type 1&2 : ± 0.1mm on Standard Surface Table
 - Straightness of type 3 : ± 0.1mm on Standard Surface Table
- *Electric insulation material*
The solid type polyimide or high conductive and high temperature epoxy systems are recommended and table 1 shows the electrical TEST.

Table 1 Routine tests required for the Heating cartridges

Electrical (made on the entire Unit – for a minimum duration of 1 minute)						
	Test		Type1	Type2	Type3	Acceptance
1	Electrical resistance of heating cartridge at 20°C		105Ω±10%	105Ω±10%	265Ω±10%	Nominal value
2	Electrical resistance between ground painting and heating cartridge power wire		> 200MΩ	> 200MΩ	> 200MΩ	Nominal value
3	HV Protection	Connector pin Σ to block wall	56kV(DC) 20kV(AC)	56kV(DC)* 20kV(AC)	10kV(DC) 3kV(AC)	DC 10min No break AC 1 min No break Leakage Current ≤ 30μA(DC) ≤ 100μA(AC)

(2) HV interface Block

The Dry-box is an air sealing container. In order to interface with the Dry-box, a feedthrough-like connector or interface block is needed. Each Dry-box requires two or four(CC) interface blocks for the connection of the heating cartridge power cables with air tightness between inside and outside the Dry-box.

(3) Power supply unit

It is enough for powering heating cartridges with an AC/DC rectifier. Single phase two wires 230V AC power will be supplied for this power supply unit from the main electric distribution. Technically type1&2 is identical except the usage.

- *AC input power:* 230 AC 50Hz single phase 2 wires including neutral wire. No or limited inrush current.
- *Electric Insulation:* The entire electric circuit component shall be insulated at 3kV DC level to the power supply chassis or earth. The chassis shall be connected to Earth ground. The output circuit shall be insulated at 3kV DC to the input circuit.
- *Over current Protection:* Two protection functions shall be implemented: Input over current at AC 230V 20A and output over current at DC 20 A for type 1&2 and DC 10A for type 3. The output over current shall be capable to cut over current coming from a significant loss of insulation at the level of the heating cartridges.

(4) High Voltage Protection Function

Figure 3 shows some protection and monitoring elements like the residual current breaker triggered on the leak current i , the insulation breaker K, the heater current measurement I and the AC/DC converter and Fuse. All these components are in the scope of the HTSCL heater contract except the heater power supply cable.

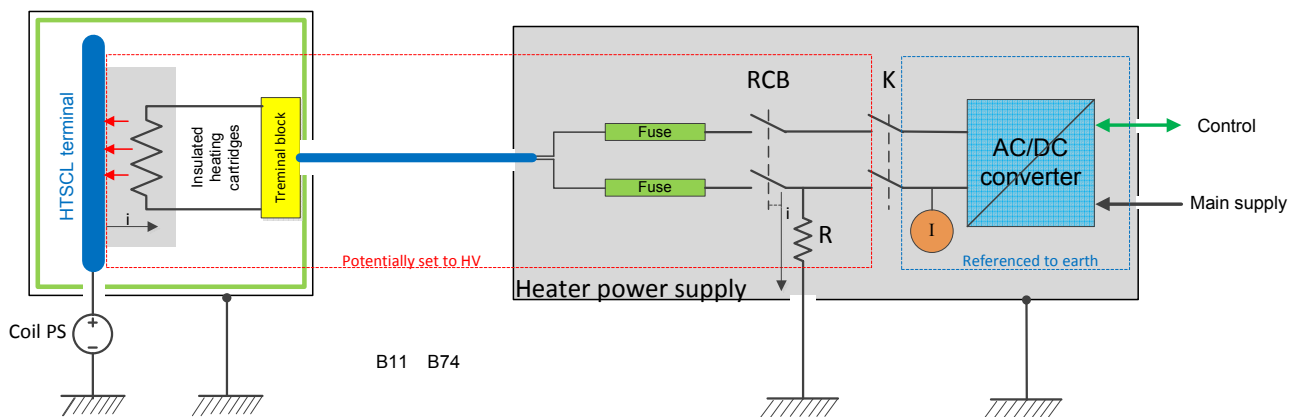

Figure 2 Functional diagram of the HTSCL terminal electric heating solution

Outline of Contract Implementation

Phase-I: Proto-type development and qualification

- Prototype design: The target there is to get a first design for manufacture of all components of the heating chain as expected in the contract scope of supply. This phase will be the opportunity to select the design options and clarify the technical points if any. The design materials (drawings, detailed design document) will be reviewed by IO before moving to the prototype manufacture.
- Prototype manufacture: one prototype of the heating chain components will be manufactured after agreement on the manufacture Quality Plan (QP) and Manufacture Inspection Plan (MIP).
- Qualification tests: The components of the heating chain prototype will be qualified by the Contractor at nominal performance for testing purpose and acceptance by IO. In addition to the tests performed by the Contractor, the compliance to High Voltage (HV) requirements will be tested by IO on ITER site: the heating chain prototype will be shipped to IO for that purpose.
- Final design for manufacture: The prototype design will be updated if required depending on the qualification tests results to get the final design for series production. The manufacture Quality Plan (QP) and Manufacture Inspection Plan (MIP) are updated accordingly if required.

Phase-II: Series production

- The phase II is performed after the successful qualification coming from the phase I.
- Production: The series production is based on the final design for manufacture and the updated and approved QP and MIP..
- Packing and delivery to the ITER site: The heater chain components are delivered as specified in the technical specification which will provided.
- Final acceptance: It will be performed by IO on ITER site by testing and visual inspection.

Time schedule

The expected duration of this contract is thirty-six (36) months from the contract placement date (T0)

The Contractor shall produce a detailed Schedule showing all phases of the Contract and showing how the overall IO Schedule will be compliant with the expected durations.

This detailed Schedule shall be submitted to the IO for approval/acceptance, before starting any work in relation to the Contract.

The following Table provides the proposal time duration for each contract phase:

Table 2: Contract phase durations

Phase	Duration
Phase-I	15 months
Phase-II until delivery to IO	18 months
Phase-II from Delivery to final Accept	03 months

Experience

The contractor and its members shall have adequate experience in CL terminal heater development and manufacturing like followings.

- Electrical Heaters and its Control
- R&D in High Voltage insulation technology over 60kV DC
- Design and Manufacture of High Voltage insulation over 60kV DC.
- High Voltage test facility (Hipot Surge etc).
- Design and Manufacture of Power supply.
- Thermal and mechanical engineering.
- Accurate or Fine Machining

Candidature

Participation is open to all legal persons participating either individually or in a grouping (consortium) which is established in an ITER Member State. A legal person cannot participate individually or as a consortium partner in more than one application or tender. A consortium may be a permanent, legally-established grouping or a grouping, which has been constituted informally for a specific tender procedure. All members of a consortium (i.e. the leader and all other members) are jointly and severally liable to the ITER Organization.

The consortium groupings shall be presented at the pre-qualification stage. The tenderer's composition cannot be modified without the approval of the ITER Organization after the pre-qualification.

Legal entities belonging to the same legal grouping are allowed to participate separately if they are able to demonstrate independent technical and financial capacities. Candidates (individual or consortium) must comply with the selection criteria. The IO reserves the right to disregard duplicated reference projects and may exclude such legal entities from the pre-qualification procedure.